



上海本菱涡旋压缩机有限公司

Shanghai Benling Scroll Compressor Company

超越期待。引领行业。创新未来。

Beyond **E**xpectations. **N**avigating **L**eadership. **I**nspiring **N**ew **G**rowth.

上海本菱涡旋压缩机有限公司

SHANGHAI BENLING SCROLL COMPRESSOR COMPANY

(Since 2009 · Shanghai)



企业介绍

PRESENTATION

目 录

01

关于我们

02

研发及产品系列

03

生产能力及追踪

04

案例展示



benling

公司背景



上海本菱涡旋压缩机有限公司

Shanghai Benling Scroll Compressor Company

超越期待。引领行业。创新未来。

Beyond Expectations. Navigating Leadership. Inspiring New Growth.



集团简介

- 双菱集团成立于1992年，注册资本82,090,000元，生产基地遍布台州、上海、江苏。
- 业务板块：
 - 家电：空调、挂壁炉、冰箱、热交换器等。
 - 汽配产品：电动汽车三合一、多合一、减速箱、**电动涡旋压缩机**、发动机。
 - 清洁能源：大型风电发电机（注册资本125,000,000元）。
 - 摩托车

双菱早期以冰箱配件为主，陆续进入空调整机及配件领域（年产销超百万台）；

- 与上海双鹿电器成立合资公司；
- 与日本日出公司成立上海双菱日出制冷配件公司；
- 与意大利公司成立戴纳斯帝（壁挂炉，产销20万台）合资公司。
- **2009年，进入新能源汽车领域，成立本菱涡旋压缩机有限公司。**
- 2019年，成立双菱亿鑫动力科技，主营业务电驱减速箱及三合一、多合一集成系统。
- **2020年与印度Vikas集团成立Vikas-Benling。**



上海本菱涡旋压缩机有限公司

Shanghai Benling Scroll Compressor Company

超越期待。引领行业。创新未来。

Beyond Expectations. Navigating Leadership. Inspiring New Growth.



双菱老厂（路桥新安南街689号，占地100余亩）



双菱新厂（吉利volvo汽车小镇，占地200余亩）



双菱集团2#厂区主入口透视图

新厂区土地总面积135991m²，总建筑面积约215474.90m²，土建总投入约29500万元。土地款与土建共计投入36801万元。目前已经建设完工，机加和电机生产线设备已搬入。



上海本菱涡旋压缩机有限公司
Shanghai Benling Scroll Compressor Company

超越期待。引领行业。创新未来。

Beyond Expectations. Navigating Leadership. Inspiring New Growth.



上海业务板块简介



1996 进入**制冷**领域

- 上海双鹿空调
- 上海双菱日出

1996 进入**机电**领域

- 上海本菱摩托车
- 上海飞羚摩托车
- 上海本菱发动机

2001 进入**清洁能源**领域

- 上海双菱风能

2009 进入**新能源汽车**领域

- 上海本菱涡旋



上海本菱涡旋压缩机有限公司

Shanghai Benling Scroll Compressor Company

超越期待。引领行业。创新未来。

Beyond Expectations. Navigating Leadership. Inspiring New Growth.



- 成立于2009年
- 注册资金15,000,000元
- 占地100亩, 66,600m²
- 员工人数约120名
- 主营业务: 电动涡旋压缩机
- 2021年销量: 8万套
- 2021营业额: 约8000万



上海本菱涡旋压缩机有限公司

Shanghai Benling Scroll Compressor Company

超越期待。引领行业。创新未来。

Beyond Expectations. Navigating Leadership. Inspiring New Growth.

产·学·研



Ph. D. Richard Longman
美国哥伦比亚大学
机械工程博士、教授

主要研究力学与控制，包括学习控制、重复控制和最优控制的理论和实践。其他研究领域包括系统识别和机器人的太空应用



Sunil Agrawal
美国哥伦比亚大学
机械工程教授

&



高橋 宏幸
Hiroyuki Takahashi
战略
教授、博士(学术)
日本中央大学

主要研究企业的行动战略，如何有效的在竞争激烈的环境下，实现企业生存和发展的「战略经营Strategic Management」



吴九汇教授
西安交通大学机械学院
振动噪声研究所
教授

主要研究振动与噪声控制，光子晶体/声子晶体理论及应用研究和纳米力学



程五民
上海应用数学及
力学研究所
教授、博导

研究计算力学及其应用软件，科学和工程计算，主要从事大跨度空间结构非线性计算、非线性微分方程数学



上海本菱涡旋压缩机有限公司

Shanghai Benling Scroll Compressor Company

超越期待。引领行业。创新未来。

Beyond Expectations. Navigating Leadership. Inspiring New Growth.

发展历程

历经十余年的坚实运营，如今的本菱已成长为行业内颇具经营规模及影响力的企业之一

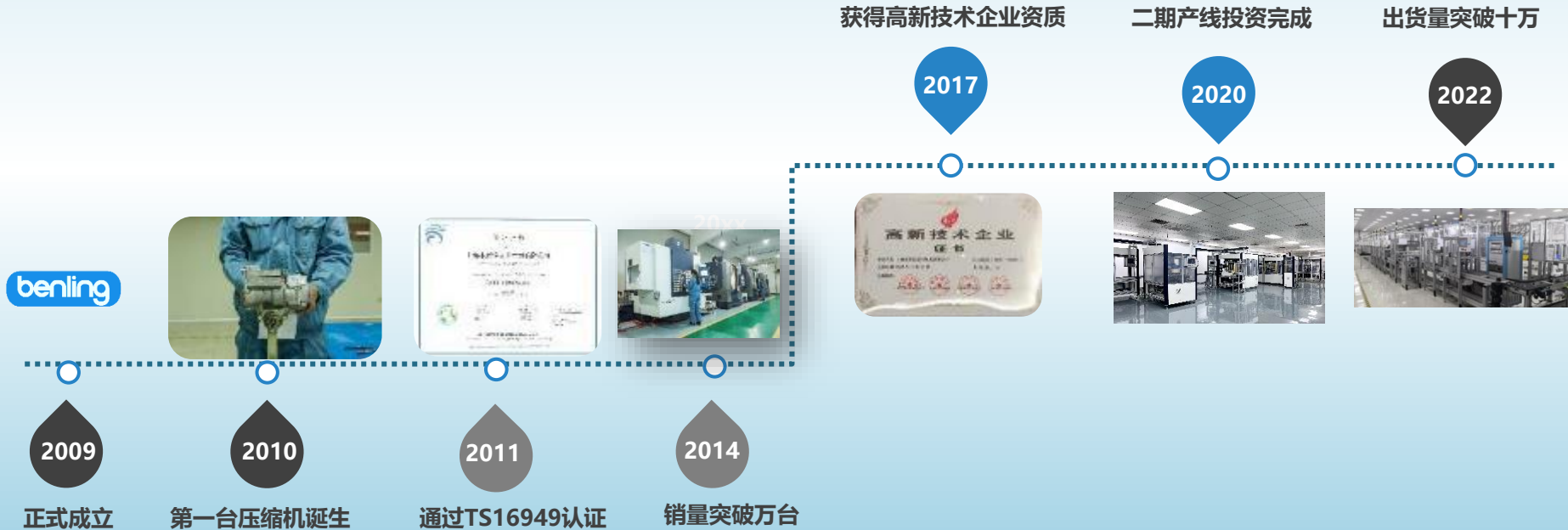



上海本菱涡旋压缩机有限公司
Shanghai Benling Scroll Compressor Company

超越期待。引领行业。创新未来。

Beyond Expectations. Navigating Leadership. Inspiring New Growth.

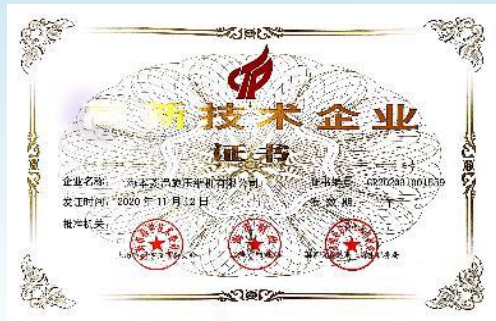

- 汽车工业协会会员单位
- 国家高新技术企业
- 2021年上海市专精特新企业
- 2021年上海市高新技术成果转化百佳项目
- 2021年度奉贤区四新经济示范单位
- 2023年奉贤区科技小巨人企业
- IATF16949体系认证
- ISO14001体系认证
- 国际贯标体系GB/T29490认证
- E-MARK-53 认证
- CE认证
- CNAS实验室体系认证 (审核中)
- ...



上海本菱涡旋压缩机有限公司
Shanghai Benling Scroll Compressor Company

超越期待。引领行业。创新未来。

Beyond Expectations. Navigating Leadership. Inspiring New Growth.

自主创新能力是我司发展壮大的关键，
迄今为止，上海本菱已获得33项授权专利，
申报审核中5项，发明专利3项。





上海本菱涡旋压缩机有限公司

Shanghai Benling Scroll Compressor Company

超越期待。引领行业。创新未来。

Beyond **E**xpectations. **N**avigating **L**eadership. **I**nspiring **N**ew **G**rowth.

官网及线上渠道：



Company official website :

www.benling-sh.com



Alibaba :

<https://chinabenling.en.alibaba.com/>



1688 :

<https://shop3263081t849u2.1688.com>

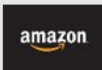

Amazon :

www.amazon.com/shops/benling



Instagram :

benlingcompressor

<https://instagram.com/benlingcompressor?igshid=MzRIODBINWFIZA==>



Facebook:

benling57483303



上海本菱涡旋压缩机有限公司

Shanghai Benling Scroll Compressor Company

超越期待。引领行业。创新未来。

Beyond **E**xpectations. **N**avigating **L**eadership. **I**nspiring **N**ew **G**rowth.



研发及产品系列



上海本菱涡旋压缩机有限公司

Shanghai Benling Scroll Compressor Company

超越期待。引领行业。创新未来。

Beyond Expectations. Navigating Leadership. Inspiring New Growth.

开发过程:CAD

CAD软件

- UG NX
- CAXA
- SOLIDWORKS
- CATIA

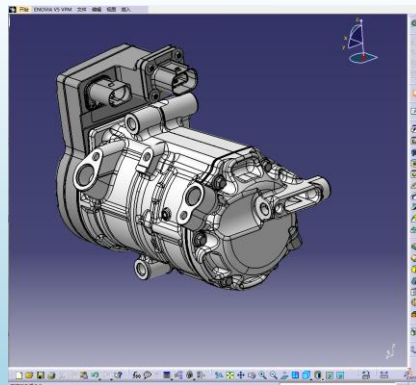
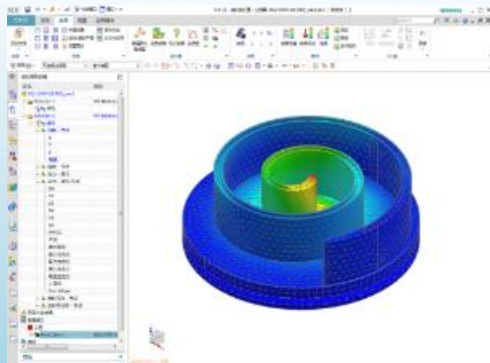
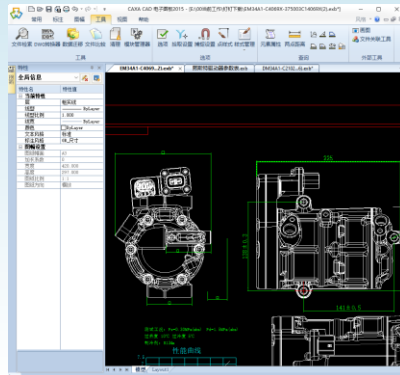
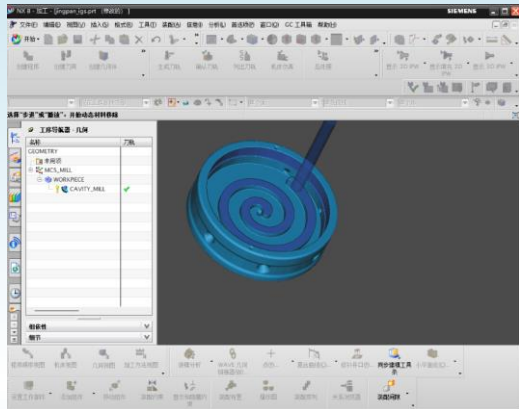

开发过程:CAE

举例：核心部件缸体及涡旋模拟仿真

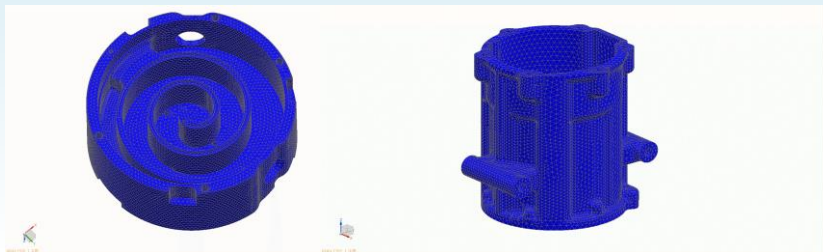

- 由于铝的线膨胀率高，使得缸体及涡旋在大范围温度区间工作的可靠性变成一项挑战
- 针对不同的工况，尤其是高温高压工况，通过模拟仿真对涡旋盘的细节进行优化设计，保证不同应用下的可靠性。对缸体静应力刚性模拟分析，确保整机的稳定可靠

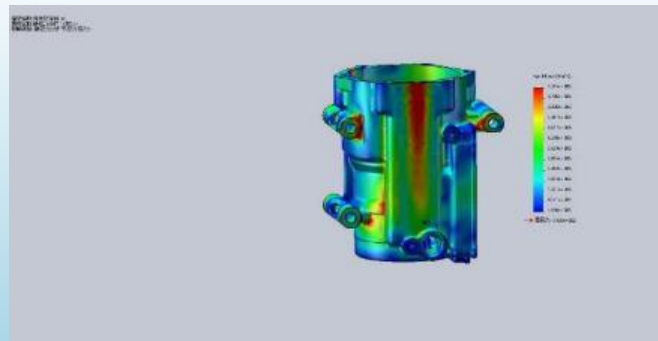
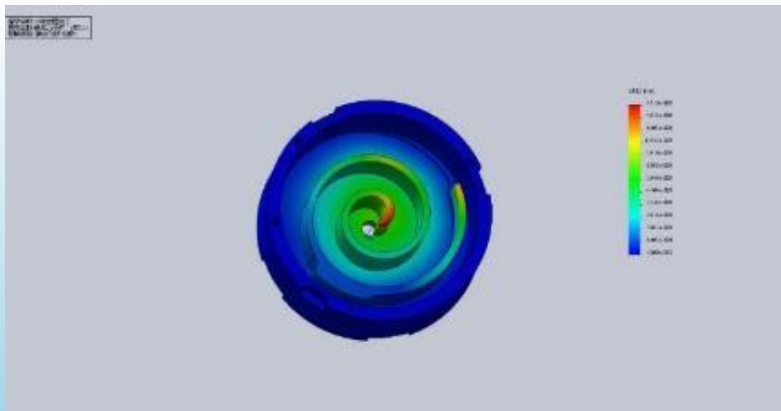

开发过程:CFD

举例：核心部件端盖及气阀模拟仿真

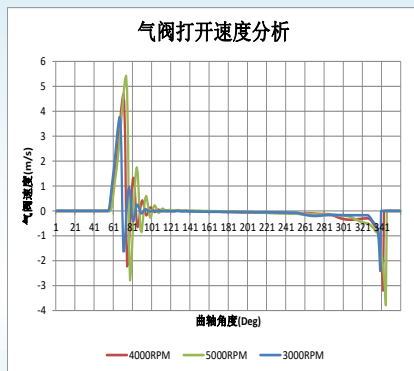
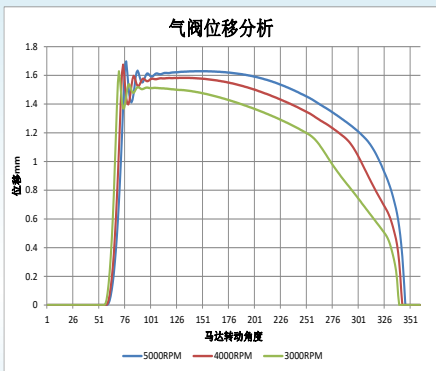

- 模拟优化端盖腔体及排气阀片设计
保证端盖腔体足够的流通面积
阀片具有适中的打开和关闭速度，降低噪音
- 总体设计使气阀的颤振进一步减弱

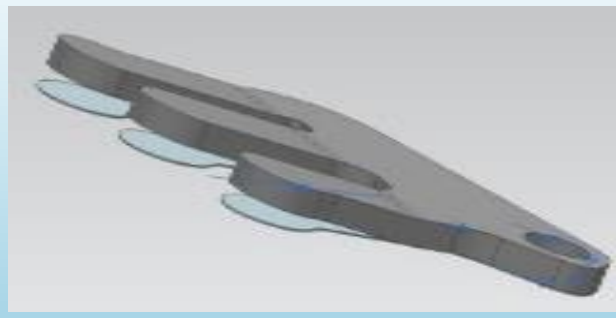
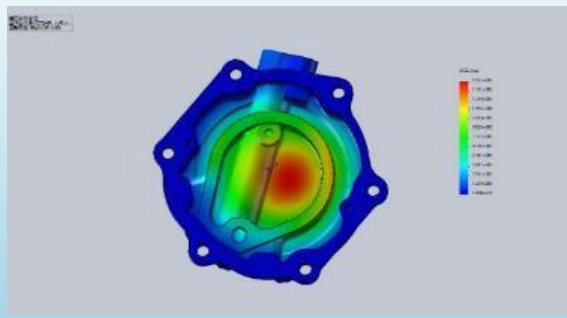
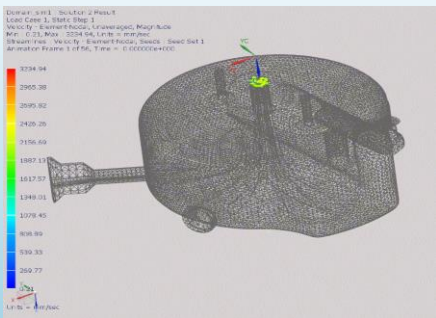

➤ 整机-电机-控制器设计匹配框架

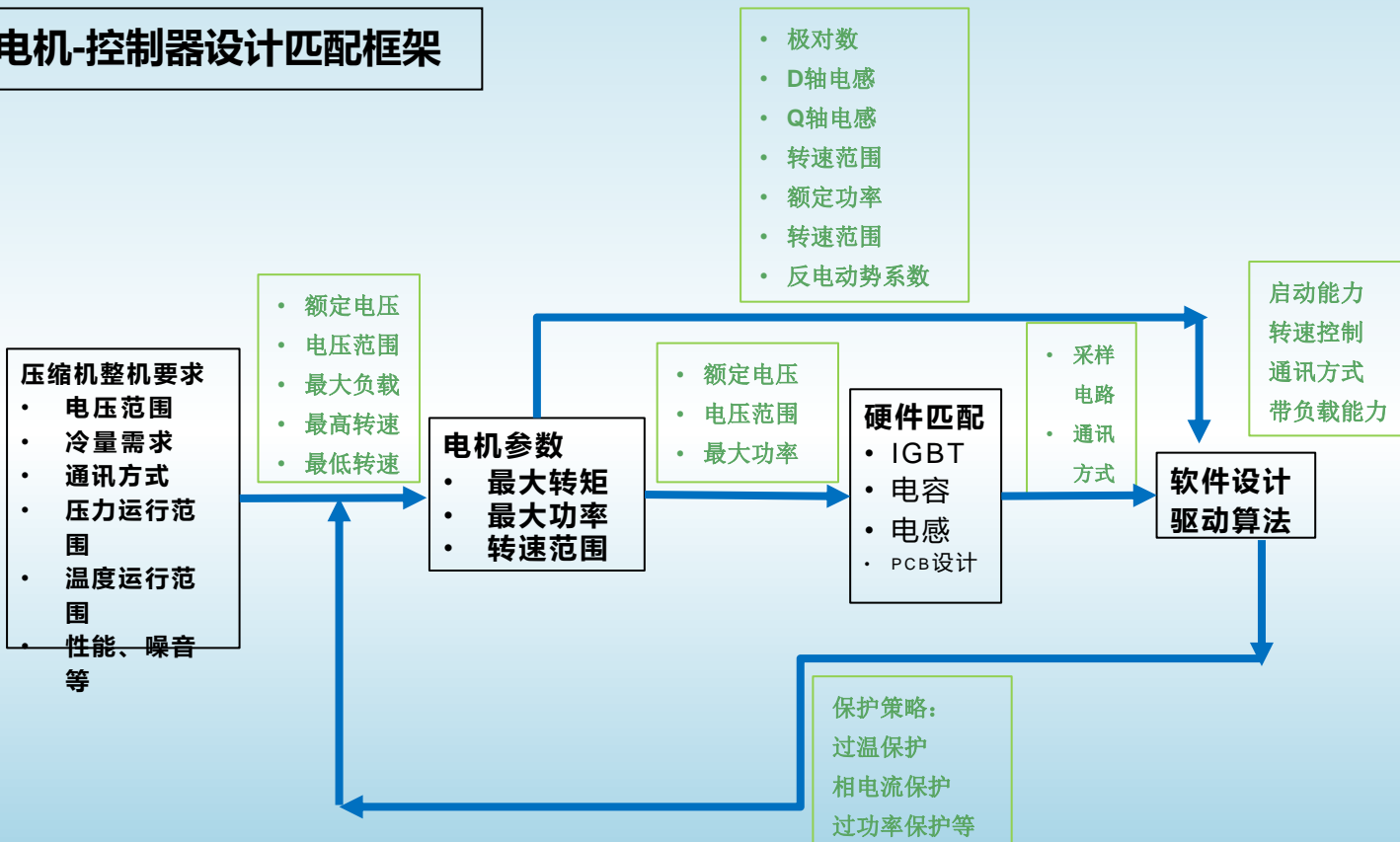



上海本菱涡旋压缩机有限公司

Shanghai Benling Scroll Compressor Company

超越期待。引领行业。创新未来。

Beyond Expectations. Navigating Leadership. Inspiring New Growth.

【产品规格】



规格	DM18	DM24
排量	18cc	24cc
控制器/电机	一体式	一体式
转速范围	2000rpm~6000rpm	2000rpm~6000rpm
最大制冷量/工作电流	2900W (6000rpm) /83A	4000W (6000rpm) /62A
最大输入电流	120A	90A
电源电压	DC10V~DC420V	DC20V~DC32V
能效比 COP (W/W)	2.0@Pd/Ps=1.5/0.3MPaA SH/SC=10/5℃	2.0@Pd/Ps=1.5/0.3MPaA SH/SC=10/5℃
防水防尘要求	IP67	
连续工作温度	-20℃~+85℃	
保存周围温度	-40℃~+120℃	
冷媒	R134a/R1234yf	
冷冻油/注入量	PVE68/100cc	PVE68/100cc
压缩机重量	5.5kg (含冷冻油)	5.8kg (含冷冻油)



上海本菱涡旋压缩机有限公司

Shanghai Benling Scroll Compressor Company

超越期待。引领行业。创新未来。

Beyond Expectations. Navigating Leadership. Inspiring New Growth.



【产品规格】

规格	DM27
压缩机型式	涡旋式
排量	27cc
通信方式	CAN\PWM
转速范围	1500rpm~6000rpm
最大制冷量	4600W(6000rpm)
电源电压	DC35V~DC750V
能效比 COP (W/W)	2.0@Pd/Ps=1.5/0.3MPaA SH/SC=10/5℃
防水防尘要求	IP67
连续工作温度	-20℃~+85℃
保存周围温度	-40℃~+120℃
冷媒	R134a/R1234yf
冷冻油/注入量	PVE68/120cc
压缩机重量	6.0kg (含冷冻油)



上海本菱涡旋压缩机有限公司

Shanghai Benling Scroll Compressor Company

超越期待。引领行业。创新未来。

Beyond Expectations. Navigating Leadership. Inspiring New Growth.

【产品规格】



规格	DM34
压缩机型式	涡旋式
排量	34cc
通信方式	CAN\PWM
转速范围	1500rpm~6000rpm
最大制冷量	5800W (6000rpm)
电源电压	DC220V~DC750V
能效比 COP (W/W)	2.0@Pd/Ps=1.5/0.3MPaA SH/SC=10/5℃
防水防尘要求	IP67
连续工作温度	-20℃~+85℃
保存周围温度	-40℃~+120℃
冷媒	R134a/R1234yf
冷冻油/注入量	PVE68/140cc
压缩机重量	6.4kg (含冷冻油)



上海本菱涡旋压缩机有限公司

Shanghai Benling Scroll Compressor Company

超越期待。引领行业。创新未来。

Beyond Expectations. Navigating Leadership. Inspiring New Growth.

【产品规格】

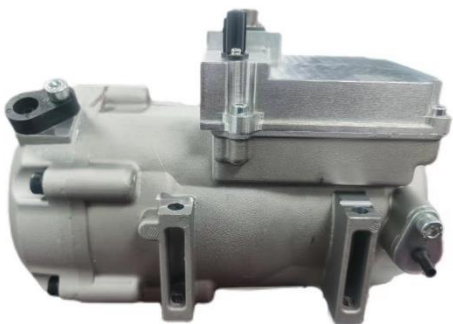

规格	CM45	CM66
排量	45cc	66cc
控制器/电机	一体式	一体式
转速范围	2000rpm~6000rpm	2000rpm~6000rpm
最大制冷量/工作电流	7700W (6000rpm) / 4.7A	11300W (6000rpm) / 6.85A
最大输入电流	8A	10A
电源电压	DC650V~DC1000V	DC650V~DC1000V
能效比 COP (W/W)	2.0@Pd/Ps=1.5/0.3MPaA SH/SC=10/5℃	2.0@Pd/Ps=1.5/0.3MPaA SH/SC=10/5℃
防水防尘要求	IP67	
连续工作温度	-20℃~+85℃	
保存周围温度	-30℃~+105℃	
冷媒	R134a/R1234yf	
冷冻油/注入量	PVE68/150cc	PVE68/180cc
压缩机重量	8.6kg (含冷冻油)	8.7kg (含冷冻油)



上海本菱涡旋压缩机有限公司

Shanghai Benling Scroll Compressor Company

超越期待。引领行业。创新未来。

Beyond Expectations. Navigating Leadership. Inspiring New Growth.

【产品规格】



规格	DM80
压缩机型式	涡旋式
排量	80cc
通信方式	CAN\PWM
转速范围	3000rpm~6000rpm
最大制冷量	28200W(6000rpm)
电源电压	DC400V~750V
能效比 COP (W/W)	3.1@Pd/Ps=1.5/0.3MPaA SH/SC=10/5℃
防水防尘要求	IP67
连续工作温度	-20℃~+85℃
保存周围温度	-40℃~+120℃
冷媒	R134a/R407C
冷冻油/注入量	PVE68/800cc
压缩机重量	17.5kg (含冷冻油)



上海本菱涡旋压缩机有限公司

Shanghai Benling Scroll Compressor Company

超越期待。引领行业。创新未来。

Beyond Expectations. Navigating Leadership. Inspiring New Growth.

技术储备

- CO2 压缩机 (R744) 及对应系统;
- R1234YF冷媒及压缩机;
- 1000V超高电压平台;
- 碳化硅模块及扁线电机;
- 轴装9600RPM max压缩机

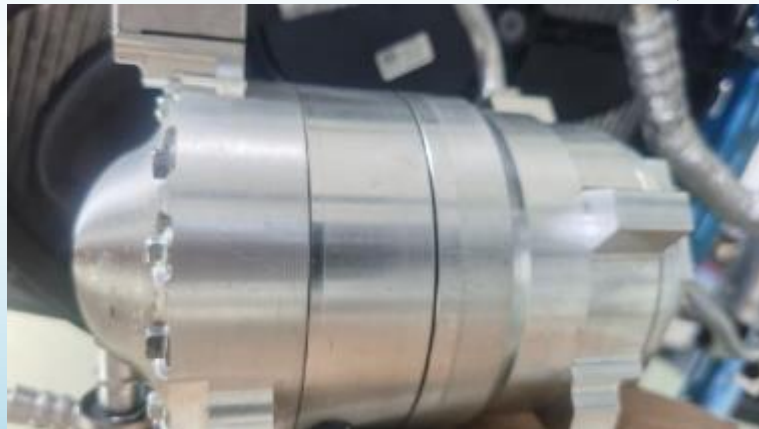



上海本菱涡旋压缩机有限公司

Shanghai Benling Scroll Compressor Company

超越期待。引领行业。创新未来。

Beyond **E**xpectations. **N**avigating **L**eadership. **I**nspiring **N**ew **G**rowth.



生产能力及数据追踪



上海本菱涡旋压缩机有限公司

Shanghai Benling Scroll Compressor Company

超越期待。引领行业。创新未来。

Beyond Expectations. Navigating Leadership. Inspiring New Growth.

生产流程



粗加工生产线



精加工生产线



清洗烘干线



库存管理



成品检测线



整机组装线

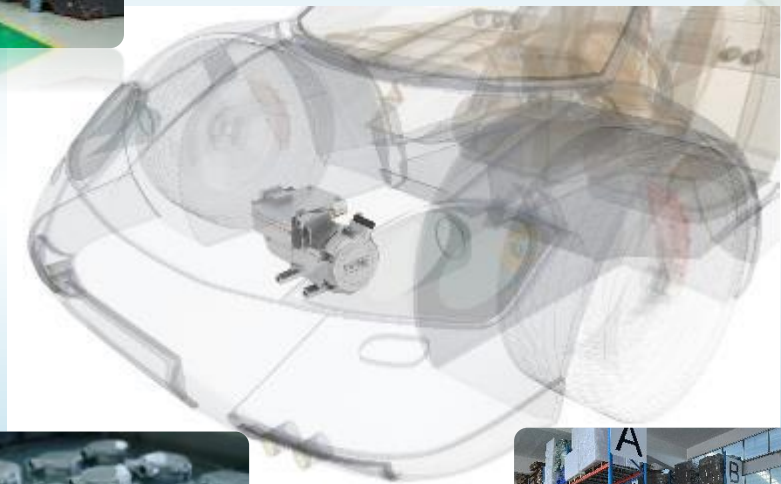



上海本菱涡旋压缩机有限公司

Shanghai Benling Scroll Compressor Company

超越期待。引领行业。创新未来。

Beyond Expectations. Navigating Leadership. Inspiring New Growth.





上海本菱涡旋压缩机有限公司
Shanghai Benling Scroll Compressor Company

超越期待。引领行业。创新未来。

Beyond Expectations. Navigating Leadership. Inspiring New Growth.

试验及验证能力



性能测试台

供应商：上海原知
可进行制冷、制热工况测试
测量范围：1000~10000W



性能测试台

供应商：合肥通用
可进行制冷工况测试
测量范围：2000~10000W

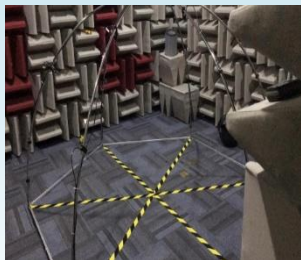

半消音室

供应商：艾佛尔
本底噪声 $\leq 18\text{dB(A)}$;
10点半球法噪声采集



冷热冲击试验箱

供应商：巨为仪器
温度范围： $-40^{\circ}\text{C} \sim +150^{\circ}\text{C}$;



三坐标测量仪

供应商：海克斯康
分辨率： $< 0.1\mu\text{m}$
最大允许误差： $2.3+3.3\text{L}/1000\mu\text{m}$



高低温试验箱

供应商：巨为仪器
高低温存储及交变湿热试验；
温度范围： $-40^{\circ}\text{C} \sim +100^{\circ}\text{C}$;
湿度范围：20%~98%。



盐雾试验箱

供应商：广东高天
中性盐雾试验箱；
温度： $10 \sim 55^{\circ}\text{C}$ 。



氦气检漏仪

供应商：安徽大信
检验精度： $5 \times 10^{-13}\text{Pa}\cdot\text{m}^3/\text{S}$

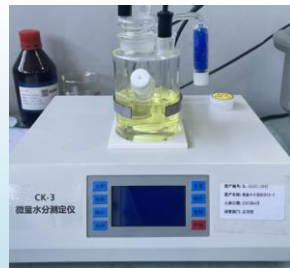

微量水分测定仪

供应商：精中
测量范围：0.0001%-100%
灵敏度： $0.1\mu\text{gH}_2\text{O}$

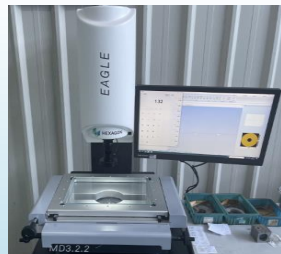

自动影像仪

供应商：海克斯康
测量精度： $3\mu\text{m}$
分辨率： $1\mu\text{m}$



上海本菱涡旋压缩机有限公司
Shanghai Benling Scroll Compressor Company

超越期待。引领行业。创新未来。

Beyond Expectations. Navigating Leadership. Inspiring New Growth.



布氏硬度测试计

供应商：巨为仪器
硬度范围：8-650HBW；



洛氏硬度测试计

供应商：巨为仪器
硬度范围：20-70HRC；



老化寿命测试台

供应商：上海源知
测量范围：0.4~30KW
电压范围：0~1000V，200A max



三坐标测量仪

供应商：海克斯康
分辨率：$0.1\mu\text{m}$
最大允许误差：2.3+3.3L/1000 μm

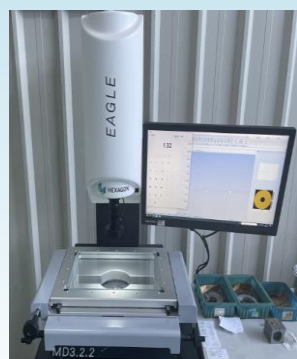

自动影像仪

供应商：海克斯康
测量精度：3 μm
分辨率：1 μm



供应商：美国PCB
用于压缩机工作状态下的激振力测试；

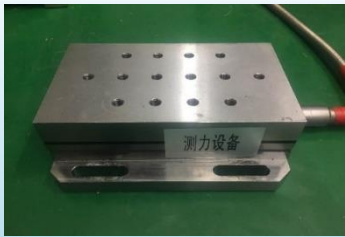

供应商：美国PCB
用于压缩机工作状态下激振力的测试。



供应商：美国PCB
12通道的数据采集前端；
可采集噪声、振动加速度、压力脉动、激振力等信号；



老化寿命测试台
测量范围：2KW~8KW
电压范围：10~800V

数据追踪

- Benling产品的关键零部件及关键工序均采用QR-CODE+RFID数据追踪系统。根据伺服压机传感器将数据回传至服务器，并在日后可追踪到所有零部件生产状态。

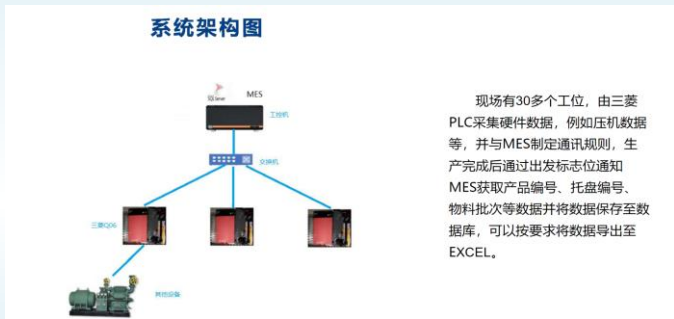

admin;

生产管理

工单管理

数据查询

产品状态修改

条码追溯

设备管理

用户管理

参数下发 x 条码追溯 x

条码追溯

G02 0145#202303171584#AP400 L02

进油量测量 转子组装 电阻焊接 电压检测 PCB板螺丝拧紧 转子、前盖轴子压装 后盖轴子压装 防水套、定子装配 泵头螺打拧紧 泵头装配打螺柱

湿区测试 干区测试 综合性能测试

字段名	值	参考值	fieldName
1 产品类型	400.1		
2 设备名称	综合性能测试		
3 工位号	OP404-2		
4 生产时间	2023-04-03 16:00:05		
5 是否合格	不合格		
6 状态			
7 机身二维码	G02 0145#202303171584#AP400 L02.001R01		设置
8 电压	13.48	11-13	设置
9 电流	0.73	0.35-2	设置
10 流量	-0.82	-10-1000	设置



上海本菱涡旋压缩机有限公司

Shanghai Benling Scroll Compressor Company

超越期待。引领行业。创新未来。

Beyond Expectations. Navigating Leadership. Inspiring New Growth.

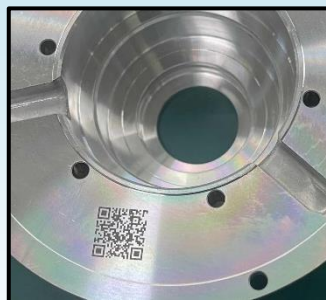

- ① 几乎涵盖所有的零件的批次追踪;
- ② 核心零件均有涵盖生产数据的二维码;
- ③ 数据包含生产人员信息;

壳体轴承	P*	217*
机架轴承	P*	321*
动盘轴承	P*	331*
电气密封环	P*	017*
高压盖密封垫	P*	055*
排气管	P*	103*
安全阀	P*	111*
密封接线座	P*	213*
接线座卡环	P*	214*
接线座密封圈	P*	218*
缓冲阀片	P*	301*
偏心轮	P*	303*

曲轴	P*	313*
机架卡环	P*	322*
轴封	P*	323*
衬套	P*	332*
耐磨片	P*	349*
静盘阀片	P*	341*
限位板	P*	342*
排油滤网(小钢幅)	P*	344*
泄油滤网	P*	345*
静盘密封圈	P*	347*
线束密封塞	P*	512*
冷冻机油	P*	046*
导热硅脂	P*	503*

零件名称	批次/单	零件类别
壳体	D*	212*
定子	D*	410*
转子	D*	460*
机架	D*	326*
动盘	D*	334*
静盘	D*	353*
高压盖	D*	102*
驱动器	D*	008*





上海本菱涡旋压缩机有限公司

Shanghai Benling Scroll Compressor Company

超越期待。引领行业。创新未来。

Byond **E**xpectations. **N**avigating **L**eadership. **I**nspiring **N**ew **G**rowth.



客户案例



上海本菱涡旋压缩机有限公司

Shanghai Benling Scroll Compressor Company

超越期待。引领行业。创新未来。

Beyond Expectations. Navigating Leadership. Inspiring New Growth.

销售网络



• 庞大的销售网络

通过不懈的努力和发展，产品质量得到了广大客户的认可，不仅在国内市场取得了稳固的市场根基，而且逐渐将销售网络扩大到了世界各个地区，还远销至海外18个国家近200家合作公司，与美国、英国、法国、澳大利亚等多家知名企业有密切的合作。

• 齐全的产品线

由于产品线多样化，业务范围也从乘用车扩展到大巴、工程车、冷藏车、机械设备和驻车空调系统。



驻车空调系统



机械设备散热



冷藏车空调制冷



大巴车空调制冷



乘用车空调制冷



工程车空调制冷



上海本菱涡旋压缩机有限公司

Shanghai Benling Scroll Compressor Company

超越期待。引领行业。创新未来。

Beyond Expectations. Navigating Leadership. Inspiring New Growth.

欧洲



美洲



亚洲



benling

上海本菱涡旋压缩机有限公司

Shanghai Benling Scroll Compressor Company

超越期待。引领行业。创新未来。

Beyond Expectations. Navigating Leadership. Inspiring New Growth.

中国本土



benling

上海本菱涡旋压缩机有限公司

Shanghai Benling Scroll Compressor Company

超越期待。引领行业。创新未来。

Beyond Expectations. Navigating Leadership. Inspiring New Growth.



塔塔集团
印度最大的集团公司
旗下拥有31家上市公司。

马恒达
印度十强企业，
本土汽车制造企业中排行第二。



TATA TIAGO



资质 emc认证



配套 2017年3月首次赴印度进行技术交流，确认初期产品方案

SOP 2018年1月正式进入量产阶段，并保持稳步增长

2017年与印度塔塔集团旗下塔塔汽车，达成合作意向。





上海本菱涡旋压缩机有限公司

Shanghai Benling Scroll Compressor Company

超越期待。引领行业。创新未来。

Beyond Expectations. Navigating Leadership. Inspiring New Growth.



越南Vin-fast
VF31、VF34、VF35、VF36



benling

上海本菱涡旋压缩机有限公司

Shanghai Benling Scroll Compressor Company

超越期待。引领行业。创新未来。

Beyond Expectations. Navigating Leadership. Inspiring New Growth.

WULING MOTORS



五菱汽车

柳州五菱汽车G系列、P系列电动物流车底盘





上海本菱涡旋压缩机有限公司

Shanghai Benling Scroll Compressor Company

超越期待。引领行业。创新未来。

Beyond Expectations. Navigating Leadership. Inspiring New Growth.



马勒&大众-MAN卡车

benling

上海本菱涡旋压缩机有限公司

Shanghai Benling Scroll Compressor Company

超越期待。引领行业。创新未来。

Beyond Expectations. Navigating Leadership. Inspiring New Growth.

橙仕

山东豪驰·橙仕汽车
全平台独供



福汽新龙马
NLM MOTOR



启腾M70L-EV电动物流车

benling

上海本菱涡旋压缩机有限公司

Shanghai Benling Scroll Compressor Company

超越期待。引领行业。创新未来。

Beyond Expectations. Navigating Leadership. Inspiring New Growth.



全平台独供



benling

上海本菱涡旋压缩机有限公司

Shanghai Benling Scroll Compressor Company

超越期待。引领行业。创新未来。

Beyond Expectations. Navigating Leadership. Inspiring New Growth.



Haima
海马汽车

全平台独供



样品阶段

- 2014年3月发送RFQ
- 经过考查验证, 于2014年6月采购样机

小批量阶段

- 技术交流, 拜访海马汽车现场
- 海马通过测试, 验证性实验和装车测试





上海本菱涡旋压缩机有限公司

Shanghai Benling Scroll Compressor Company

超越期待。引领行业。创新未来。

Beyond Expectations. Navigating Leadership. Inspiring New Growth.



PROAIR VANS

ProAir has selected Personal Full-Size and Mini-Vans for ProAir's 8-year and 10-year warranties for over 20 years. ProAir has a solution to your van heating and air conditioning needs. No matter if it's a simple fix or the need of a compact heating and cooling unit, contact a ProAir sales representative to see the right call for your needs.

[READ MORE](#)

HEATERS 	CONDENSERS 	ESPAR 	EVAPORATORS 	LOUVERS
--------------------	-----------------------	------------------	------------------------	--------------------

TCCI ABOUT PRODUCTS & SERVICES MARKET APPLICATIONS REFERENCE LIBRARY



Parking Coolers Fresco 	A/C for light vehicles and Trucks 	A/C for Buses
A/C for Special vehicles 	Refrigeration Frosty 	A/C for agricultural and Earth-moving machines
A/C for tramways, Trains and metro 	A/C for Military vehicles 	Aeronautics

服务于欧美多家空调系统供应商，并保持批量合作状态。

海外Tier-2累计供货量：55000台



上海本菱涡旋压缩机有限公司

Shanghai Benling Scroll Compressor Company

超越期待。引领行业。创新未来。

Beyond Expectations. Navigating Leadership. Inspiring New Growth.

 pranav vikas (India) Pvt. Ltd

VIKAS-BENLING PRIVATE LIMITED

1ST FLOOR, ADMIN BLOCK -B, PLOT NO 45-46, Gate No. 4 INDUSTRIAL AREA, NIT FARIDABAD, Faridabad, Haryana-121001.

- 本土化生产目标，提升当地整车厂竞争力，进一步降低生产成本。
- 项目：
 1. TATA 72V
 2. Mahindra 72V
 3. GENSOL
 4. TAFE
 5. SGMW Air
 6. JBM





上海本菱涡旋压缩机有限公司

Shanghai Benling Scroll Compressor Company

超越期待。引领行业。创新未来。

Byond **E**xpectations. **N**avigating **L**eadership. **I**nspiring **N**ew **G**rowth.

THANKS

Q&A

上海本菱涡旋压缩机有限公司

电话：021-57483303 地址：上海市奉贤区金汇镇大叶公路5001号